

GS 04L01A01-00E

OVERVIEW

The DX100 is a DAQSTATION that displays real-time measured data on a color LCD and saves data on a 3.5-inch floppy disk, PCMCIA ATA flash memory card or Zip disk. It can be hooked up to network via Ethernet, which enables to inform by E-mail and to monitor on Web site as well as to transfer files by using FTP. Also, it can communicate with FOUNDATION™ Fieldbus and Modbus.

It comes with a two, four, six or twelve-channel. As the input signal, a DC voltage, thermocouple, resistance temperature detector, or contact signal can be set to each channel. The data saved on a floppy disk can be converted by data conversion software to Lotus 1-2-3, Excel, or ASCII format file, facilitating processing on a PC. Not only this, the Viewer software allows a PC to display waveforms on its screen and to print out waveforms.



Inputs : VDC (DC voltage), TC (thermocouple), RTD (resistance temperature detector), DI (digital input for event recording), DCA (DC current with external shunt resistor attached)

STANDARD SPECIFICATIONS

General Specifications

Construction

- Mounting : Flush panel mounting (on a vertical plane)
Mounting may be inclined downward up to 30 degrees from a horizontal plane.
- Allowable Panel Thickness :
2 to 26 mm
- Material : Case : Drawn steel
Bezel : Polycarbonate
Front Filter : Polycarbonate
- Color : Case : Grayish blue green
(Munsell 2.0B 5.0/1.7 or equivalent)
Bezel : Charcoal grey light
(Munsell 10B 3.6/0.3 or equivalent)
- Front Panel :
Water and dust-proof
(based on IEC529-IP65, NEMA No. 250 TYPE 4 (except external icing test), except for side-by-side mounting)
- Dimensions :
144(W) x 144(H) x 218(D) mm
- Weight : DX102 : approx. 2.9 kg
DX104 : approx. 3.0 kg
DX106 : approx. 3.0 kg
DX112 : approx. 3.0 kg

Input

- Number of Inputs :
DX102 : two channels
DX104 : four channels
DX106 : six channels
DX112 : twelve channels
- Measurement Interval :
DX102, DX104 : 125 ms
DX106, DX112 : 1 s (2 s when an A/D integration time is set to 100 ms)

Input type	Range	Measuring range	
DCV	20 mV	-20.00 to 20.00 mV	
	60 mV	-60.00 to 60.00 mV	
	200 mV	-200.0 to 200.0 mV	
	2 V	-2.000 to 2.000 V	
	6 V	-6.000 to 6.000 V	
	20 V	-20.00 to 20.00 V	
	50 V	-50.00 to 50.00 V	
TC	R ¹	0.0 to 1760°C	32 to 3200°F
	S ¹	0.0 to 1760°C	32 to 3200°F
	B ¹	0.0 to 1820°C	32 to 3200°F
	K ¹	-200.0 to 1370°C	-328 to 2498°F
	E ¹	-200.0 to 800°C	-328.0 to 1472.0°F
	J ¹	-200.0 to 1100°C	-328.0 to 2012.0°F
	T ¹	-200.0 to 400°C	-328.0 to 752.0°F
	N ¹	0.0 to 1300°C	32 to 2372°F
	W ²	0.0 to 2315°C	-328.0 to 4199°F
	L ³	-200.0 to 900°C	-328.0 to 1652.0°F
U ³	-200.0 to 400°C	-328.0 to 752.0°F	
RTD ⁵	Pt100 ⁴	-200.0 to 600°C	-328.0 to 1112.0°F
	JPt100 ⁴	-200.0 to 550°C	-328.0 to 1022.0°F
DI	DCV input (TTL)	OFF : less than 2.4 V ON : more than 2.4 V	
	Contact input	Contact on/off	

*1 R, S, B, K, E, J, T, N : IEC584-1 (1995), DIN IEC584, JIS C1602-1995
 *2 W : W-5% Rd/W-26% Rd (Hoskins Mfg. Co.), ASTM E988
 *3 L : Fe-CuNi, DIN43710, U : Cu-CuNi, DIN43710
 *4 Pt100 : JIS C1604-1997, IEC751-1995, DIN IEC751-1996
 JPt100 : JIS C1604-1989, JIS C1606-1989
 *5 Measuring current : i = 1 mA

A/D Integration Time :
 Fixed to 20 ms (50 Hz), 16.7 ms (60 Hz),
 100 ms (50/60 Hz for DX106/DX112), or
 AUTO selectable (automatic selection by
 detection of power supply frequency)

Thermocouple Burnout :
Burnout upscale/downscale function can be switched on/off (for each channel). Burnout upscale/downscale selectable

Filter :

DX102, DX104 :

On/off selectable for each channel
Time constant : selectable from 2, 5, and 10 seconds

DX106, DX112 :

Moving average on/off selectable for each channel, moving average cycles 2 to 16 selectable

Calculation :

Differential computation :

Between any two channels
Available for VDC, TC, and RTD ranges.

Linear scaling :

Available for VDC, TC, and RTD ranges.
Scaling limits : -30000 to 30000
Decimal point : user-selectable
Engineering unit : user-definable, up to 6 characters

Square root :

Available for VDC range.
Scaling limits : -30000 to 30000
Decimal point : user-selectable
Engineering unit : user-definable, up to 6 characters

Display

Display unit :

5.5-inch TFT color LCD
(QVGA, 320 x 240 pixels)

Note In the part of crystal display, there are some pixels that can't always turn on or off. Please understand that the brightness of screen looks uneven because of characteristics of crystal display, but it is not out of order.

Display color :

Trend/Bargraph : Selectable from 12 color
Background : White or black selectable

Trend display :

Trend display direction :
vertical or horizontal selectable

Number of indication channels :
6 channels per display (maximum)

All channels indication :
12 channels (maximum)

Number of display :
4 displays (4 groups)

Line width : 1, 2, and 3 pixels selectable

Waveform span rate :

DX102, DX104:
15, 30 sec., 1, 2, 5, 10, 20, 30 min., 1, 2, 4, 10 hours/div selectable

DX106, DX1012 :

1, 2, 5, 10, 20, 30 min., 1, 2, 4, 10 hours/div selectable

Bargraph display :

Direction : Vertical or horizontal selectable
Number of indication channels :
6 channels per display (maximum)

Number of display :
4 displays (4 group)

Scales : 4 to 12 selectable

Reference position :

Left, right or center (only for horizontal)

Display renewal rate : 1 s

Digital indication :

Number of indication channels :
6 channels per display (maximum)

Number of display : 4 displays (4 group)

Display renewal rate : 1 s

Overview display :

Number of indication channels :
Measuring values and alarm status of all channels

Information display :

Alarm summary display :
Display the list of alarm summary

Message summary display :
Display the list of messages and time.
Jump to trend display by cursor pointing.

Memory information :

Display the file list in internal memory.
Jump to trend display by cursor pointing.

Medium information :

Display the file list in external memory.
Jump to trend display by cursor pointing.

Tags :

Number of characters :
16 characters maximum

Other display contents :

Memory status, Scale values, (0 and 100%, display on/off selectable), Scales (maximum 6 scales), grid lines (number of divisions selectable from 4 to 12), hour : minutes on grid, trip levels (line widths are selectable from 1, 2 and 3 pixels), messages (up to eight different messages of up to 16 characters for each), alarm indication

Data referencing function :

Display the retrieved data (display data or event data) from internal or external memory.

Display format :

Whole display or divided to 2 areas

Time axis operation :

Display magnification or reduction, scroll by key operation

Display auto scroll function :

Display group of monitor display (trend display, bargraph display and digital display) automatically changes in a preset interval (5, 10, 20, 30, s and 1 min).

LCD saver function :

The LCD backlight automatically dims if no key is touched for a certain preset time (can be set from 1, 2, 5, 10, 20, and 60 min).

Temperature unit :

°C or °F selectable

Language : English, French and German selectable

Data Saving Function

External storage medium :

Selectable from :
1) 3.5-inch floppy disk (2HD, 1.44 MB)
2) PCMCIA ATA flash memory card
3) Zip disk

Saving method :

Manual or automatic selectable

Manual saving :

Data saving by inserting external memory medium

Automatic saving :

Display data :

Periodic saving (10 min to 31 days) or key operation to external memory

Event data :

In case of trigger free...Periodic saving (3 min to 31 days) or key operation to external memory
 In case of using trigger...Save the data when sampling is finished

Data Saving Period :

Display data file : Linked with the waveform span rate

Event file : Linked with the specified sampling period

Event File Sampling Period :

DX102, DX104 :

Selectable from 125, 250, 500 ms, and 1, 2, 5, 10, 30, 60, 120, 300, 600 s

DX106, DX112 :

Selectable from 1, 2, 5, 10, 30, 60, 120, 300, and 600 s

Measurement data File :

The following two file types can be created.

- Event file (stores instantaneous values sampled periodically at a specified sampling rate)
- Display data file (stores the maximum and minimum values for each waveform span rate from among measured data sampled at measurement intervals)

Files can be created in the following combinations.

- (a) Event file (only for trigger mode) + display data file
- (b) Display data file only
- (c) Event file only

Data format : YOKOGAWA standard format (Binary)

Data per channel :

Display data file : Measurement data...4 byte/data, mathematical data...8 byte/data

Event data file :

Measurement data...2 byte/data, mathematical data...4 byte/data

Sampling time :

The sampling time per file (or floppy disk) during manual data saving can be determined by the formula "number of data items per channel x interval of data saving."

This logic is explained in more detail below :

1) When handling display data files only

If we assume that the number of measuring channels is 12, the number of computing channels is 6, and the display update interval is 30 min/div (60 sec waveform span rate), then :

Number of data items per channel = 1,200,000 bytes/(12 x 4 bytes + 6 x 8 bytes) = 12,500 data items*

*Maximum number of data is 100,000.

Sampling time per file = 12,500 x 60 sec = 750,000 sec = approx. 8 days

2) When handling event files only

If we assume that the number of measuring channels is 12, the number of computing channels is 6, and the data saving interval is 1 sec, then :

Number of data items per channel = 1,200,000 bytes/(12 x 2 bytes + 6 x 4 bytes) = 25,000 data items*

*Maximum number of data is 120,000.

Sampling time per file = 25,000 x 1 sec = 25,000 sec = approx. 7 hours

3) When handling both display data files and event files

The sampling time is calculated by defining the size of data items in a display data file as 900,000 bytes and the size of data items in an event data file as 300,000 bytes. The method of calculation is the same as shown above.

*Maximum number of data for display data file is 75,000.

Maximum number of data for event file is 30,000.

If a Zip drive or an ATA memory card is being used, at least two volumes of the above-mentioned files (the quantity depends on the medium's capacity) are saved in that medium.

Examples of Sampling Time :

In case measurement ch = 4 ch, mathematical ch = 0 ch

Only display data file

(approx.)

Waveform span rate (min/div)	1 min	5 min	20 min	30 min	60 min	240 min
Data saving period (s)	2 s	10 s	40 s	60 s	120 s	480 s
Sampling time	41 h	8 days	34 days	52 days	104 days	416 days

Only event data file

(approx.)

Data saving period	125ms	500ms	1 s	5 s	30 s	120 s
Sampling time	4.2 h	16 h	33 h	6 days	41 days	166 days

Display data file + Event data file

Display data file

(approx.)

Waveform span rate (min/div)	1 min	5 min	20 min	30 min	60 min	240 min
Data saving period (s)	2 s	10 s	40 s	60 s	120 s	480 s
Sampling time	31 h	6 days	26 days	39 days	78 days	312 days

Event data file

(approx.)

Data saving period	125ms	500ms	1 s	5 s	30 s	120 s
Sampling time	1 h	4.2 h	8.3 h	41 h	10 days	41 days

In case measurement ch = 6 ch, mathematical ch = 0 ch

Only display data file

(approx.)

Waveform span rate (min/div)	1 min	5 min	20 min	30 min	60 min	240 min
Data saving period (s)	2 s	10 s	40 s	60 s	120 s	480 s
Sampling time	27 h	5 days	23 days	34 days	69 days	277 days

Only event data file

(approx.)

Data saving period	1 s	5 s	10 s	30 s	60 s	120 s
Sampling time	27 h	5 days	11 days	34 days	69 days	138 days

Display data file + Event data file

Display data file

(approx.)

Waveform span rate (min/div)	1 min	5 min	20 min	30 min	60 min	240 min
Data saving period (s)	2 s	10 s	40 s	60 s	120 s	480 s
Sampling time	20 h	4 days	17 days	26 days	52 days	208 days

Event data file

(approx.)

Data saving period	1 s	5 s	10 s	30 s	60 s	120 s
Sampling time	6.9 h	34 h	2 days	8 days	17 days	34 days

Manual sample data :

Trigger : Key operation or remote contact

Data format :

ASCII

Max. number of data :

50 data

TLOG data (only for MATH option) :
 Trigger : Time up of TLOG interval
 Report data (only for MATH option) :
 Types : Hourly, daily, hourly + daily, daily + weekly
 and daily + monthly
 Data format :
 ASCII
 Trigger function :
 Event file : Selectable from FREE, TRIG or ROTATE
 Display data file + Event file :
 Selectable from TRIG or ROTATE
 Display hard copy :
 Trigger : Key operation
 Data format :
 png format
 Output : External memory medium or communication interface

Alarm Function

Number of alarm levels :
 Up to four levels for each channel
 Alarm types :
 High and low limits, differential high and low limits, high and low rate-of-change limits and delay high and low
 Interval time of rate-of-change alarms :
 The measurement interval times 1 to 15
 Alarm delay time :
 1 to 3600 s
 Display : The alarm status (type) is displayed in the digital value display area upon occurrence of an alarm. A common alarm indication is also displayed. The alarming behavior : non-hold or hold-type can be selectable for common to all channels.
 Hysteresis :
 On (0.5% of display span)/off selectable (common to all channels and alarm levels)
 Outputs :
 Number of points :
 2, 4, or 6 points (optional)
 Relay action :
 Energized/deenergized and hold/non-hold selectable.
 Memory : The times of alarm occurrences/recoveries, alarm types, etc. are stored in the memory. (Up to 120 latest alarm events are stored.)

Communication Functions

Connection :
 Ethernet (10BASE-T)
 Protocols : SMTP, HTTP1.0, FTP, TCP, UDP, IP, ARP, ICMP
 E-mail inform function:
 Recipient address :
 2 address groups (plural address can be put within 150 words in each groups)
 Kinds of inform :
 the following information can be informed by E-mail, selectable from inform/misinform for each group
 Alarm inform :
 inform in occurring alarm/canceling alarm
 System inform :
 inform in recovering power failure/inform the time of recovering, inform the rest of time before rewriting on inside memory (manual save mode) inform the rest of amount in reaching 90% of media volume (auto save mode)

Scheduled time inform:
 inform the moment value at a certain time or interval
 Report inform :
 inform report data in report timeup (/M1 is equipped)
 Web server function :
 display an image, alarm information, and moment values of DX screen by browser soft (Microsoft Internet Explorer 5.0). message input from browser screen
 FTP client function :
 file auto-transfer from DX (display data file, event file, and report file)
 FTP server function :
 manual-transfer of file in the outside media from host computer, directory operation, information of file elimination and of rest of amount of memory in media
 Real time monitoring function :
 real time monitoring DX data by communication (Yokogawa private protocol)

Power Supply

Rated power supply :
 100 to 240 VAC (automatic switching)
 Allowable power supply voltage range :
 90 to 132 or 180 to 250 VAC
 Rated power supply frequency :
 50/60 Hz (automatic switching)
 Power consumption :

Supply voltage	LCD save mode	Normal	Max.
100 VAC	30 VA	32 VA	45 VA
240 VAC	42 VA	47 VA	62 VA

Other Specifications

Clock : With calendar function (year of grace)
 The time can be adjusted by a remote contact (with the remote option).
 Summer/winter time :
 Summer and wintertime can be set.
 Accuracy of clock :
 ±100 ppm, excluding a delay (of 1 second, maximum) caused each time the power is turned on.
 Memory backup :
 A built-in lithium battery backs up the setup parameters (battery life : approximately ten years at room temperature).
 Key lock function :
 ON/OFF and password can be set.
 Log in function :
 Power on with log out mode and all key operations are not permitted.
 "User name", "User ID" and "password" are required to enter the operation mode.
 And key lock by password can be set to prevent to change settings.
 Insulation resistance :
 Each terminal to ground terminal :
 20 MΩ or greater (at 500 VDC)
 Dielectric strength :
 Power supply to ground terminal :
 1500 VAC (50/60 Hz), 1 min
 Contact output terminal to ground terminal :
 1500 VAC (50/60 Hz), 1 min
 Measuring input terminal to ground terminal :
 1500 VAC (50/60 Hz), 1 min

- Between measuring input terminals :
 1000 VAC (50/60 Hz), 1 min (except for b-terminal of RTD input of DX106 and DX112)
- Between remote control terminal to ground terminal :
 500 VDC, 1 min

- Mounting position :
 Can be inclined up to 30 deg backward.
 Mounting at an angle away from the perpendicular is not acceptable.
- Warm-up time :
 At least 30 min after power on

Safety and EMC Standards

- CSA: CSA22.2 No1010.1 installation category II*¹,
 pollution degree 2*²
- UL: UL61010B-1 (CSA NRTL/C)
- CE:
 EMC directive:
 EN61326 compliance (Emission: Class A, Immunity: Annex A)
 EN61000-3-2 compliant
 EN61000-3-3 compliant
 EN55011 compliant, Class A Group 1
- Low voltage directive:
 EN61010-1 compliant, measurement category II*³, pollution degree 2*²
- C-Tick: AS/NZS 2064 compliant, Class A Group 1
- *1: Installation Category (Overvoltage Category) II
 Describes a number which defines a transient overvoltage condition. It implies the regulation for impulse withstand voltage. "II" applies to electrical equipment which is supplied from fixed installations like distribution boards.
- *2: Pollution Degree
 Describes the degree to which a solid, liquid, or gas which deteriorates dielectric strength or surface resistivity is adhering. "2" applies to normal indoor atmosphere. Normally, only non-conductive pollution occurs.
- *3: Measurement Category II
 Applies to measuring circuits connected to low voltage installation, and electrical instruments supplied with power from fixed equipment such as electric switchboards.

Normal Operating Conditions

- Power voltage :
 90 to 132 or 180 to 250 VAC
- Power supply frequency :
 50 Hz \pm 2%, 60 Hz \pm 2%
- Ambient temperature :
 0 to 50°C (when using FDD or Zip : 5 to 40°C)
- Ambient humidity :
 20% to 80% RH (at 5 to 40°C)
- Vibration : 10 to 60 Hz, 0.2 m/s² or less
- Shock : Not acceptable
- Magnetic field :
 400 AT/m or less (DC and 50/60 Hz)
- Noise :
 Normal mode (50/60 Hz) :
 VDC : The peak value including the signal must be less than 1.2 times the measuring range.
 TC : The peak value including the signal must be less than 1.2 times the measuring thermal electromotive force.
 RTD : 50 mV or less
- Common mode noise voltage (50/60 Hz) :
 250 Vrms AC or less for all ranges
- Maximum noise voltage between channels (50/60 Hz) :
 250 Vrms AC or less

Standard Performance

Measuring and Recording Accuracy :

The following specifications apply to operation of the recorder under standard operation conditions.

Temperature :

23 ± 2°C

Humidity : 55% ± 10% RH

Power supply voltage :

90 to 132 or 180 to 250 VAC

Power supply frequency :

50/60 Hz ± 1%

Warm-up time :

At least 30 min.

Other ambient conditions such as vibration should not adversely affect recorder operation.

Input	Range	Measurement accuracy (digital display)	Max. resolution of digital display
DCV	20 mV	±(0.1% of rdg + 2 digits)	10 μV
	60 mV		10 μV
	200 mV		100 μV
	2 V		1 mV
	6 V		1 mV
	20 V		10 mV
	50 V		±(0.1% of rdg + 3 digits)
TC (Excluding the reference junction compensation accuracy)	R	±(0.15% of rdg + 1°C)	0.1°C
	S	However, R, S : ±3.7°C at 0 to 100°C, ±1.5°C at 100 to 300°C	
	B	B : ±2°C at 400 to 600°C (Accuracy at less than 400°C is not guaranteed.)	
	K	±(0.15% of rdg + 0.7°C) However, ±(0.15% of rdg + 1°C) at -200 to -100°C	
	E	±(0.15% of rdg + 0.5°C)	
	J	±(0.15% of rdg + 0.5°C)	
	T	However, ±(0.15% of rdg + 0.7°C) at -200 to -100°C	
	N	±(0.15% of rdg + 0.7°C)	
	W	±(0.15% of rdg + 1°C)	
	L	±(0.15% of rdg + 0.5°C)	
RTD	U	However, ±(0.15% of rdg + 0.7°C) at -200 to 100°C	
	Pt100	±(0.15% of rdg + 0.3°C)	
	JPt100		

Measurement accuracy in case of scaling (digits) :

= measurement accuracy (digits) x scaling span (digits)/measurement span (digits) + 2 digits

Decimals are rounded off to the next highest number.

Reference junction compensation :

INT (internal)/EXT (external) selectable (common for all channels)

Reference junction compensation accuracy (above 0°C) :

Types R, S, B, W : ±1°C

Types K, J, E, T, N, L, U : ±0.5°C

Maximum allowable input voltage :

±10 VDC (continuous) for less than 2 VDC ranges and TC ranges

±60 VDC (continuous) for more than 6 VDC ranges

Input resistance :

Approximately 10 MΩ or more for DCV ranges of 2 VDC or less and TC
Approximately 1 MΩ for more than 6 VDC ranges

Input source resistance :

VDC, TC : 2 kΩ or less

RTD : 10 Ω or less per wire (The resistance of all three wires must be equal.)

Input bias current :

10 nA or less

Maximum common mode noise voltage :

250 Vrms AC (50/60 Hz)

Maximum noise voltage between channels :

250 Vrms AC (50/60 Hz)

Interference between channels :

120 dB (when the input source resistance is 500 Ω and the inputs to other channels are 30 V)

Common mode rejection ratio :

120 dB (50/60 Hz ± 0.1%, 500 Ω imbalance between the minus terminal and ground)

Normal mode rejection ratio :

40 dB (50/60 Hz ± 0.1%)

Effects of Operating Conditions

Ambient temperature :

With temperature variation of 10°C :

 $\pm(0.1\%$ of rdg + 1 digit) or less

Excluding the error of reference junction compensation

For RTD inputs :

 $\pm(0.1\%$ of rdg + 2 digits) or less

Power supply :

With variation within 90 to 132 V and 180 to 250 VAC (50/60 Hz) :

 ± 1 digit or lessWith variation of ± 2 Hz from rated power frequency (at 100 VAC) : $\pm(0.1\%$ of rdg + 1 digit) or less

Magnetic field :

AC (50/60 Hz) and DC 400 A/m fields :

 $\pm(0.1\%$ of rdg + 10 digits) or less

Input source resistance :

(1) VDC range

With variation of +1 k Ω :Ranges of 2 V or less : within ± 10 μ VRanges of 6 V or greater : -0.1% of rdg or less

(2) TC range

With variation of +1 k Ω :Within ± 10 μ V (± 100 μ V when the burnout upscale/downscale function is switched on)

(3) RTD range (Pt100)

With variation of 10 Ω per wire (resistance of all three wires must be equal) : $\pm(0.1\%$ of rdg + 1 digit) or lessWith maximum difference of 40 m Ω between wires : approximately $\pm 0.1^\circ\text{C}$ **Transport and Storage Conditions**

The following specifies the environmental conditions required during transportation from shipment to the start of service and during storage as well as during transportation and storage if this instrument is temporarily taken out of service.

No malfunction will occur under these conditions without serious damage, which is absolutely impossible to repair; however, calibration may be necessary to recover normal operation performance.

Ambient temperature :

 -25° to 60°C

Humidity : 5% to 95% RH (No condensation is allowed.)

Vibration : 10 to 60 Hz, 4.9 m/s² maximumShock : 392 m/s² maximum (while being packed)**SPECIFICATIONS OF OPTIONAL FUNCTIONS****Alarm Output Relays (/AR1, /AR2, /A3) :**

An alarm signal is output from the rear panel as a relay contact signal.

/AR1 and /AR2 includes remote control functions (/R1)

Relay contact rating :

250 VDC/0.1 A (for resistance load) 250 VAC (50/60 Hz)/3 A

Terminal configuration :

SPDT (NO-C-NC). Energized-at-alarm/deenergized-at-alarm, AND/OR, and hold/non-hold actions are selectable.

Serial Communication Interface (/C2, /C3) :

This interface allows the host computer to control and make settings for the recorder as well as receive data from the recorder.

Connection :

EIA RS-232 (/C2) or RS-422-A/485 (/C3)

Protocols : YOKOGAWA private protocol, Modbus protocol

Synchronization method :

Start-stop asynchronous transmission

Connection method (RS-422-A/485) :

4-wire half-duplex multi-drop connection (1 : N where N = 1 to 31)

Transmission speed :

1200, 2400, 4800, 9600, 19200 or 38400 bps

Data length :

7 or 8 bits

Stop bit : 1 bit

Parity : Odd, even, or none

Communication distance (RS-422-A/485) :

Up to 1.2 km

Communication mode :

ASCII for input/output for control and setting

ASCII or binary for output of measured data

Modbus communication :

operation mode :

RTU MASTER or RTU SLAVE

RTU MASTER :

data acquisition of 8 packsets groups the continuous register that is same type of data in a slave group can be registered in a basket group

RTU SLAVE :

output of data of measurement, computation and alarm status

FOUNDATION Fieldbus communication function (/CF1) :

The bi-directional digital communication as standard for FOUNDATION™ Fieldbus that is established by Fieldbus foundation.

Interface : FOUNDATION™ Fieldbus H1 (communication speed : 31.25 kb/s)

Physical layer type :

113 (standard-power signaling, bus powered, non I.S.)

Communication line condition:

power supply---9 to 32 VDC, current supply---16.5 mA (Max.)

Signal insulation :

communication terminal to grand terminal, dielectric strength 500 Vrms (50/60 Hz, 1 min)

Device : Link master

Function block :

AI block :

8 blocks (1 block for each channels)
Transfer the data of measurement and computation of DX to other instruments

MAI block :

1 block (8 channels)
Transfer the data of measurement and computation of DX to other instruments

MAO block :

1 block (8 channels)
Display and record the data of other instruments

Fail/Memory End Output (/F1) :

The relay contact output on the rear panel indicates the occurrence of a system error, the rest of memory media.

Manual save mode:

relay output before the specified time of starting overwriting inside memory(selectable from 1, 2, 5, 10, 20, 50, or 100 hours)

Auto save mode:

relay output when the amount of memory media reaches 90%

Relay contact rating :

250 VDC/0.1 A (for resistance load) 250 VAC (50/60 Hz)/3 A

Clamped Input Terminal (/H2) :

Clamped input terminal is used for input terminal.

Desk Top Type (/H5 [], /H5) :

Provides carrying handle and power cord.

* In case that /P1 is specified together, /H5 must be specified. Power terminal will be screw type and power code will not be provided.

Mathematical Functions (/M1) :

Used for calculating data, displaying trends and digital values, and recording calculated data assigned to channels.

Channel assignable to calculated data :

DX102, DX104 :
Up to 8 channels

DX106, DX112 :
Up to 12 channels

Operation :

General arithmetic operations :

Four arithmetic operations, square root, absolute, common logarithm, exponential, power, relational operations (>, ≥, <, ≤, =, ≠), logic operations (AND, OR, NOT, XOR)

Statistical operations :

Average, maximum, minimum and summation

Special operations : Long term rolling average

Constant : Available (Up to 12 constants)

Digital data input via communication :

Digital data via communication can be used in mathematical expression (Up to 12 data)

Remote status input :

Remote input status (0/1) can be used in mathematical expression (Up to 8 inputs)

Report functions :

Report type :

Hourly, daily, hourly + daily, daily + weekly and daily + monthly

Operation : Average, maximum, minimum and summation

Data format :

ASCII

Cu10, Cu25 RTD Input /3 leg isolated RTD Input (/N1) :

This option allows Cu10 and Cu25 inputs to be added to the standard input types.

A,B,b legs are of isolated input type for DX106 and DX112.

	Input type	Measuring range
RTD (measurement current : i = 1.25 mA)	Cu10 (GE)	-200 to 300°C
	Cu10 (L&N)	
	Cu10 (WEED)	
	Cu10 (BAILEY)	
	Cu10 : α = 0.00392 at 20°C	
	Cu10 : α = 0.00393 at 20°C	
	Cu25 : α = 0.00425 at 0°C	

Input type	Accuracy guaranteed range	Measurement accuracy
Cu10 (GE)	-70 to 170°C	±(0.4% of rdg + 1.0°C)
Cu10 (L&N)	-75 to 150°C	
Cu10 (WEED)	-200 to 260°C	
Cu10 (BAILEY)		
Cu10 : α = 0.00392 at 20°C	-200 to 300°C	±(0.3% of rdg + 0.8°C)
Cu10 : α = 0.00393 at 20°C		
Cu25 : α = 0.00425 at 0°C		

* In case that /N1 is specified, the measurement accuracy of Pt100/JPt100 RTD input will be ;
±(0.3% of rdg + 0.6°C)

3 legs Isolated RTD Input (/N2) :

A, B, b legs are of isolated input type.

*Can be specified only for DX106 and DX112.

A,B,b legs of DX102 and DX104 are isolated as standard.

24 VDC/AC Power Supply (/P1) :

Rated power supply :

24 VDC/AC

Allowable power supply voltage range :

21.6 to 26.4 VDC/AC

Dielectric strength :

Power supply to ground terminal :
500VAC

Power Consumption :

Supply voltage	LCD save mode	Normal	Max.
24 VDC	17 VA	19 VA	30 VA
24 VAC (50/60Hz)	28 VA	32 VA	45 VA

Remote Control (/R1) :

This option allows the following eight functions to be controlled remotely by a contact input:

- Start/stop of memory (level)
- Trigger for event file (trigger, 250 ms or longer)
- Time adjustment (adjusting the time to a preset time upon contact signal, trigger, 250 ms or longer)

Time of trigger-on	Processing
hh:00:00 to hh:01:59	Cut off reading of less than one minute. e.g. 10:00:50 is corrected as 10:00:00
hh:58:00 to hh:59:59	Round up reading of less than one minute. e.g. 10:59:50 is corrected as 11:00:00
hh:02:00 to hh:57:59	No process is to be performed.

- Start/stop of computation (level)
- Reset of computation data (trigger, 250 ms or longer)
- Manual data sample (trigger, 250 ms or longer)
- Message display (Up to 8 different messages can be set, trigger, 250 ms or longer)
- Load of setting parameters (Up to 3 settings can be set, trigger, 250 ms or longer)
- Alarm acknowledgement (trigger, 250 ms or longer)
- Snapshot (trigger, 250 ms or longer)

Batch Function (/BT1) :

Batch number function are available.

Batch number function :

Batch number (max. 16 characters + 4 figures lot number) and comment (max. 32 characters x 3 lines) can be set in the operation mode.

Auto increment of serial number by each batch start is available.

Pre-set application name, supervisor name and manager name can be referred in the batch number entry display.

Data file :

Following information are added to the display/event data file as headers.

- User name
- Application name
- Supervisor name
- Manager name
- Batch number
- comment

24 VDC transmitter power supply (/TPS2, /TPS4)

Output voltage: 22.8 to 25.2 VDC (rated load current)

Rated output current :

4 to 20 mADC

Max. output current :

25 mADC (current to guard operation against overcurrent : approx. 68 mADC)

Allowable conductor resistance :

$RL \leq (17.8 - \text{transmitter minimum operation voltage})/0.02 \text{ A}$
(not include drop voltage with load shunt resistance)

Max. length of wiring :

2 km (CEV cable)

Insulation resistance :

output terminal to grand terminal more than 20 M Ω (500 VDC)

Dielectric strength :

output terminal to grand terminal

500 VAC (50/60 Hz, I = 10 mA), 1 min

Within output terminal

500 VAC (50/60 Hz, I = 10 mA), 1 min

■ APPLICATION SOFTWARE**DAQSTANDARD**

Operating environment

OS : Microsoft Windows 98/Me/NT4.0/2000/XP

Processor : MMX Pentium166 MHz or higher
(Pentium II 266 MHz or higher recommended)

Memory : 32 MB or more
(64 MB or more recommended)

Disk device :

CD-ROM drive that is applied to Windows 95/98/Me/NT4.0/2000

3.5" floppy disk drive (1.44 MB format)

Hard disk : Free area of at least 10 MB (100 MB or higher recommended)

Display card :

Compatible with Windows 95/98/Me/NT4.0/2000

Can display 32,000 colors or higher
(64,000 colors or higher recommended)

Printer : A printer and printer driver compatible with Windows 95/98/Me/NT4.0/2000

Basic function (packages) :

Configuration software :

external memory medium : configuration of setup and set mode

Configuration via communication :

configuration of setup and set mode without communication configuration (ex. IP address)

Data viewer:

numbers of display channels :

32 channels for each group, at most 30 group

Display function :

waveform display, digital display, circular display, list display, TLOG display, report display etc.

File connection display :

connect data files that are divided because of auto-save during continuous data collecting or power failure, and then display (can connect up to total a million)

Section computation :

Max. value, Min. value, average value, effective value, p-p value

Data conversion :

File conversion to ASCII, Lotus 1-2-3 or MS-Excel format

Print out : Print out retrieved data

■ MODEL AND SUFFIX CODES

Model code	Suffix code	Optional code	Description
DX102			DAQSTATION DX100 (2 ch)
DX104			DAQSTATION DX100 (4 ch)
DX106			DAQSTATION DX100 (6 ch)
DX112			DAQSTATION DX100 (12 ch)
External memory	-1		FDD
	-3		ATA flash memory card (with medium : CF card + adapter)
	-5		250MB Zip (with medium)
Display language	-2		English/Germany/French, deg F & Summer/winter time (with English DAQSTANDARD)
Options		/AR1	Alarm output 2 points/Remote control ^{*1*2}
		/AR2	Alarm output 4 points/Remote control ^{*1*2}
		/A3	Alarm output 6 points ^{*1*3}
		/BT1	Batch function
		/C2	RS-232 interface (including Modbus Master/Slave protocol) ^{*4*5}
		/C3	RS-422-A/485 interface (including Modbus Master/Slave protocol) ^{*4*5}
		/CF1	FOUNDATION Fieldbus ^{*4*6}
		/F1	Fail/memory end detection and output ^{*3}
		/H2	Clamped input terminal
		/H5	Desktop type (without power code, screw type power terminal) ^{*7}
		/H5[]	Desktop type (with power code) ^{*8}
		/M1	Mathematical function (with report function)
		/N1	Cu10, Cu25 RTD input/3 legs isolated RTD
		/N2	3 legs isolated RTD ^{*9}
		/P1	24 VDC/AC power supply
		/TPS2	24 VDC transmitter power supply (2 loops) ^{*10}
	/TPS4	24 VDC transmitter power supply (4 loops) ^{*11}	
	/R1	Remote control	

- *1 /AR1, /AR2, and /A3 cannot be specified together.
- *2 If /AR1 or /AR2 is specified, /R1 cannot be specified.
- *3 If /A3 is specified, /F1 cannot be specified.
- *4 /C2, /C3, and /CF1 cannot be specified together.
- *5 In case that Modbus master function is utilized, /M1 must be specified.
- *6 In case that FOUNDATION Fieldbus (/CF1) is specified, /M1 must be specified together.
- *7 In case that 24 VDC/AC power supply (/P1) and desktop type are specified together, /H5 must be specified. /P1 and /H5[] cannot be specified together.
- *8 /H5[]
 - D Power cord UL, CSA st'd
 - F Power cord VDE st'd
 - R Power cord SAA st'd
 - J Power cord BS st'd
 - H Power cord GB st'd
- *9 /N2 cannot be specified for DX102, DX104.
- *10 In case that /TPS2 is specified, /TPS4, /AR2, /A3, or /F1 cannot be specified.
- *11 In case that /TPS4 is specified, /TPS2, /AR1, /AR2, /A3, or /F1 cannot be specified.

Application Software

Model	Description	Operating System
DXA100-02	DAQSTANDARD	Windows 98/Me/NT4.0/2000/XP
WX104/CD1	DAQEXPLORER	Windows 2000/XP
DXA310-021	DAQ-PharmBio	Windows 98/Me/NT4.0/2000/XP
DXA410-02	DAQOPC (Basic)	Windows 2000/XP
DXA410-04	DAQOPC (Advanced)	Windows 2000/XP
WX101/CD1	DAQLOGGER (1600 channels)	Windows 2000/XP
WX81/CD1	DAQLOGGER Client (1600 channels)	Windows 2000/XP

■ STANDARD ACCESSORIES

Item (s)	Quantity
Mounting brackets	2
Fuse	1
Terminal screws	5
Instruction manual	1
Zip disk (250 MB)	1*1
PCMCIA ATA flash memory card (CF card + adapter)	1*2

*1 : Only for DX1[] []-5 model

*2 : Only for DX1[] []-3 model

■ OPTIONAL ACCESSORIES

Item (s)	Model (part) number	Specification
Shunt resistors (for screw input terminal)	415920	250 $\Omega \pm 0.1\%$
	415921	100 $\Omega \pm 0.1\%$
	415922	10 $\Omega \pm 0.1\%$
Shunt resistors (for clamped input terminal, /H2)	438920	250 $\Omega \pm 0.1\%$
	438921	100 $\Omega \pm 0.1\%$
	438922	10 $\Omega \pm 0.1\%$
3.5-inch floppy disks	705900	2HD (10 disks)
Zip disk	A1056MP	250 MB
Card adapter (not including CF card)	772090	–
CF card (not including adapter)	772091	128 MB
	772092	256 MB
	772093	512 MB
	772094	1 GB
Fuse	A1347EF	250 V, 1 A TL
	A1352EF	250 V, 4 A TL (for /P1)
Mounting bracket	B9900BX	–

■ DIMENSIONS

Dimensions

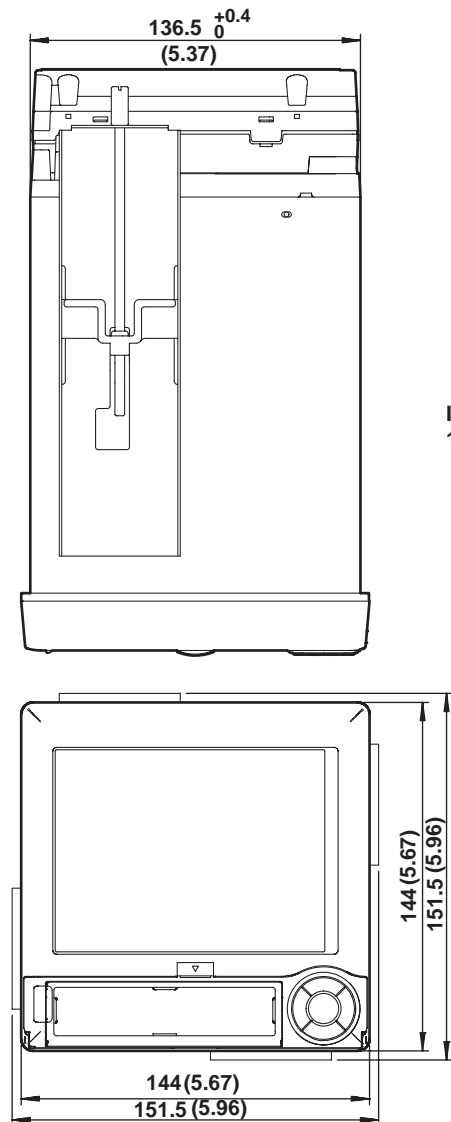

Rear View

Unit : mm
(approx. inch)

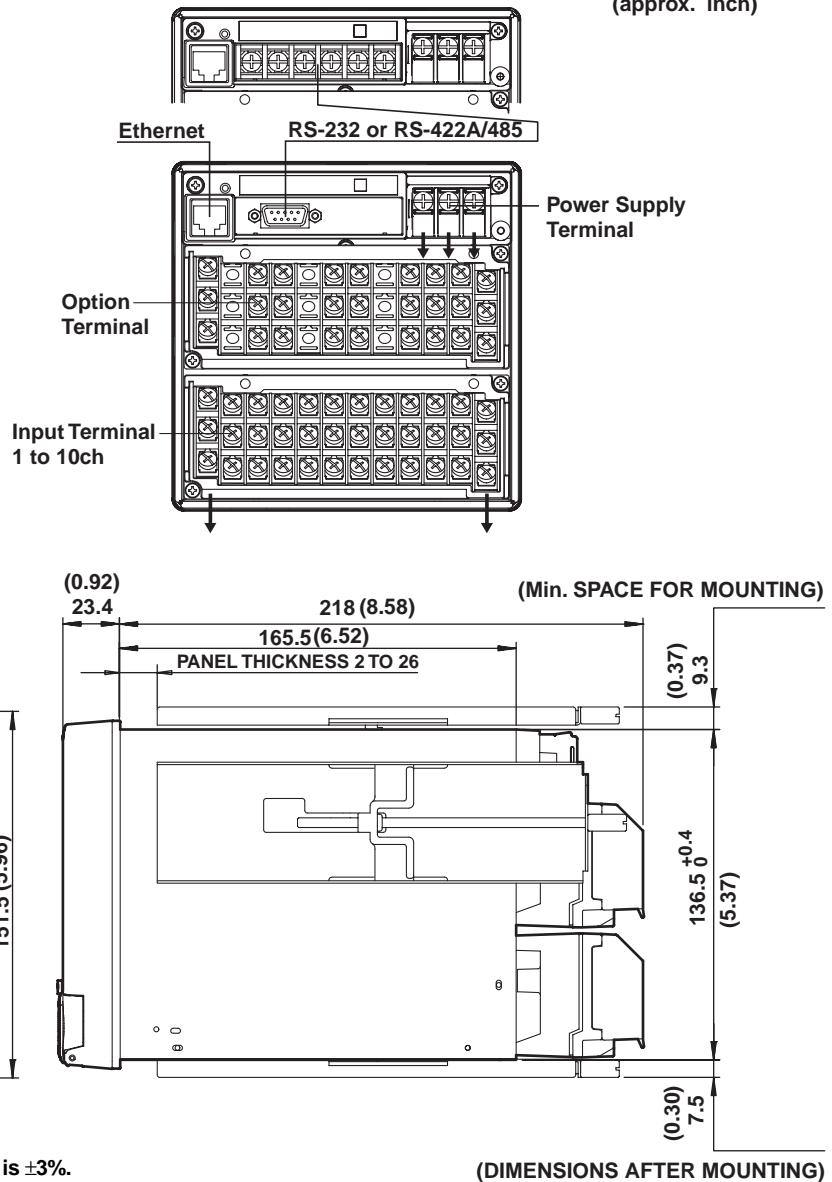

Note : If not specified, the tolerance is $\pm 3\%$.
However, for dimensions less than 10 mm, the tolerance is ± 0.3 mm.

Panel cutout

Unit : mm
(approx. inch)

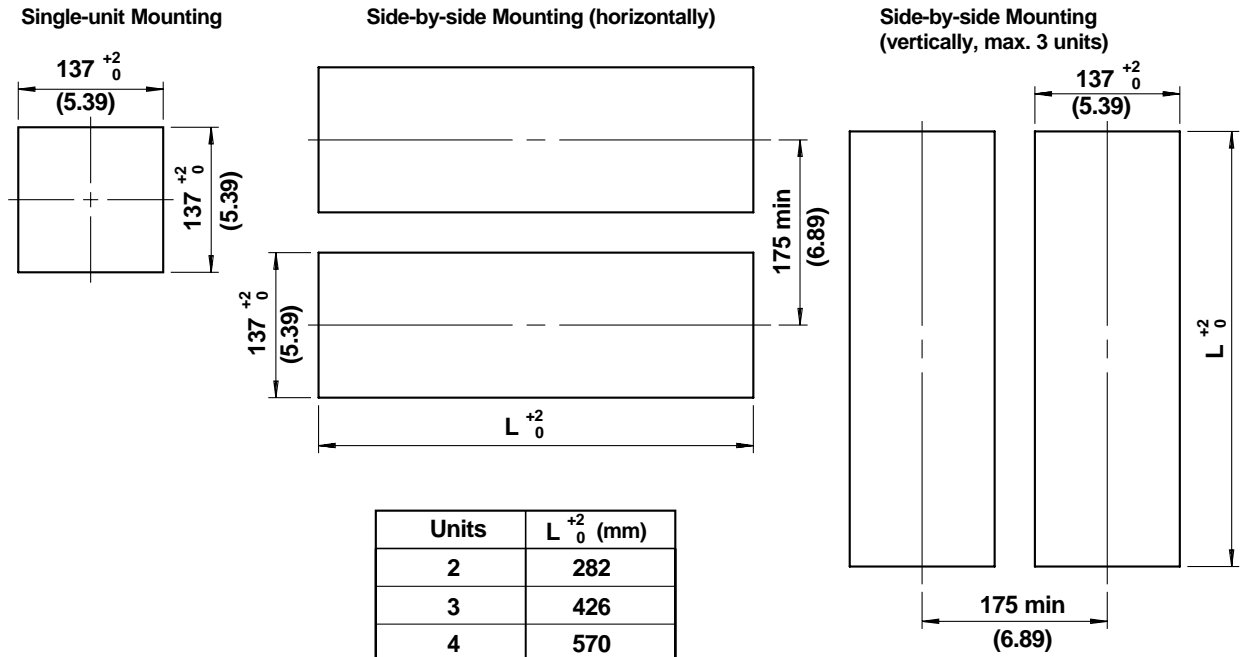

Note : If not specified, the tolerance is ±3%. However, for dimensions less than 10 mm, the tolerance is ±0.3 mm.

Desk-top type

Rear View

Unit : mm
(approx. inch)

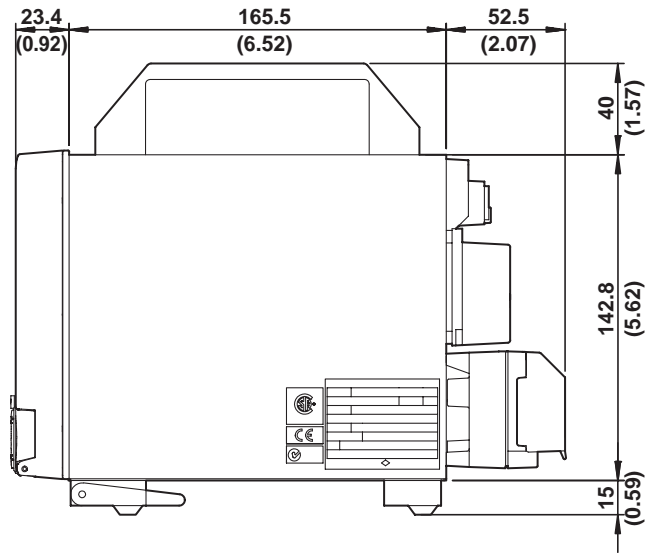
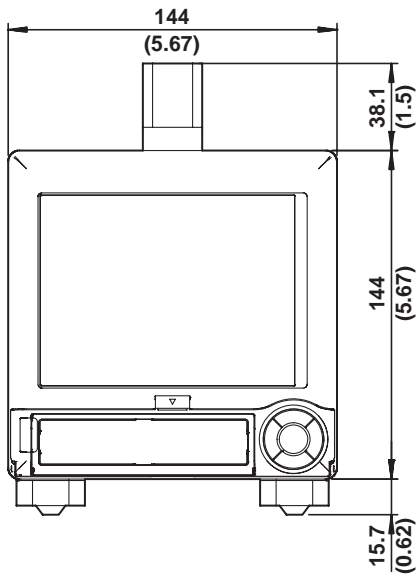
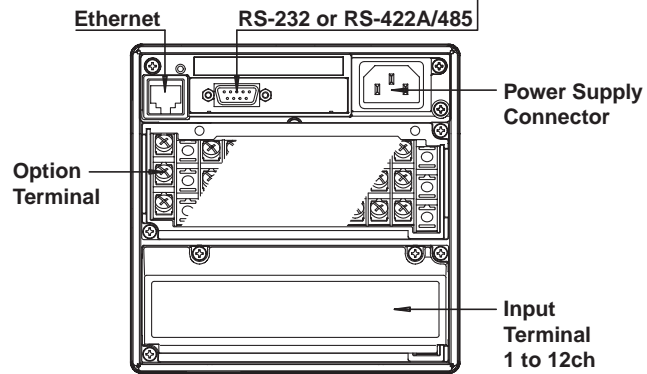
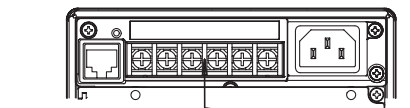
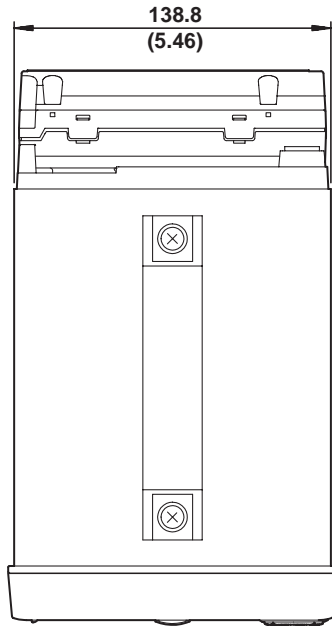

If not specified, the tolerance is $\pm 3\%$. However, in cases of less than 10 mm, the tolerance is ± 0.3 mm.

Power Supply Terminal

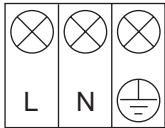

RS-422-A/485 Terminal



RS-232 Terminal

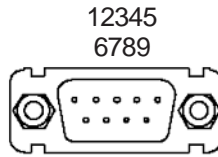

1	N.C.
2	RxD
3	TxD
4	DTR
5	GND
6	DSR
7	RTS
8	CTS
9	N.C.

FOUNDATION Fieldbus Terminal



Input Terminals

DX102, DX104 Screw-On Terminals

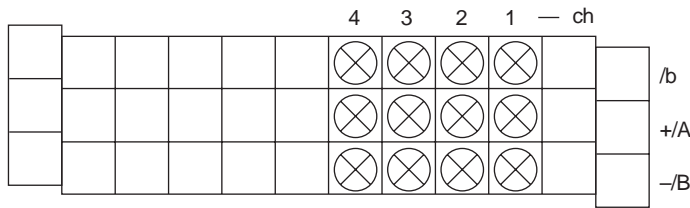

DX102, DX104, DX106 Clamped Terminals (/H2)

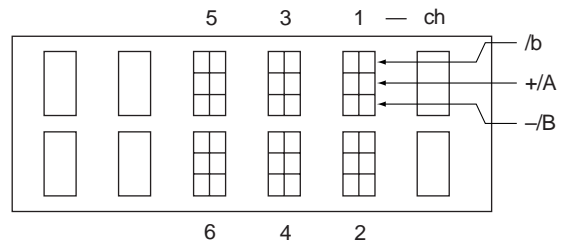

DX106 Screw-On Terminals

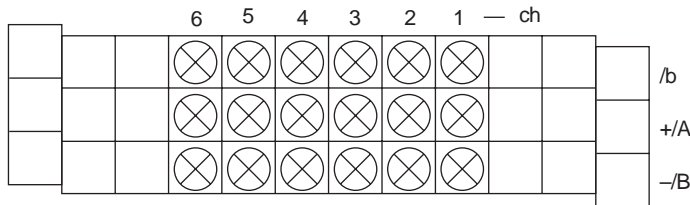

DX112 Clamped Terminals (/H2)

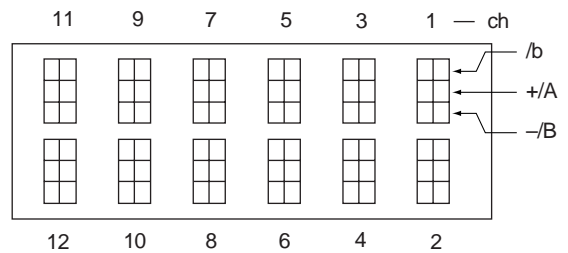

DX112 Screw-On Terminals

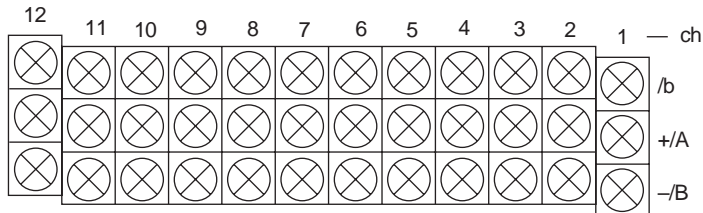

Option Terminals

/A3/R1 Combination

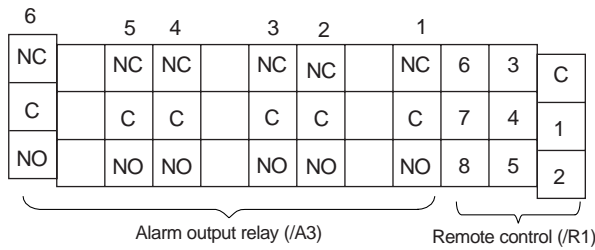

/A2/F1/R1 Combination

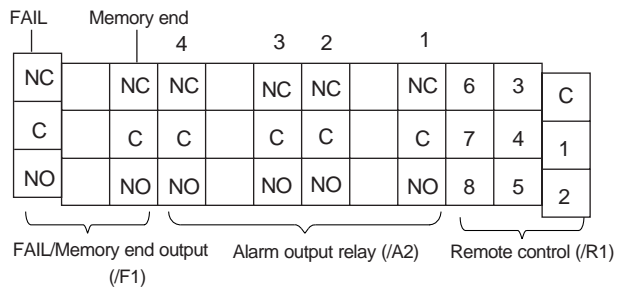

/A1/R1/TPS2, /AR1/TPS2 Combination

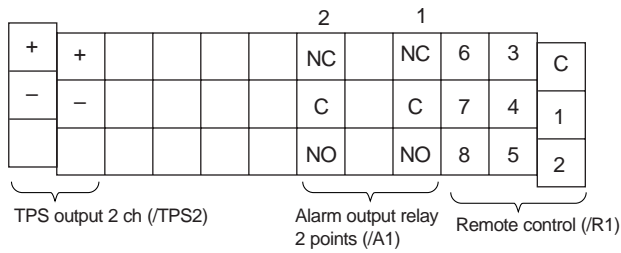

/A1/TPS2 Combination

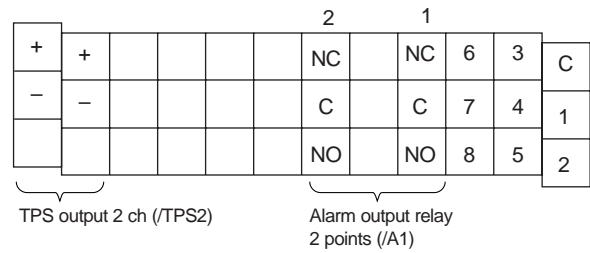

/R1/TPS2 Combination

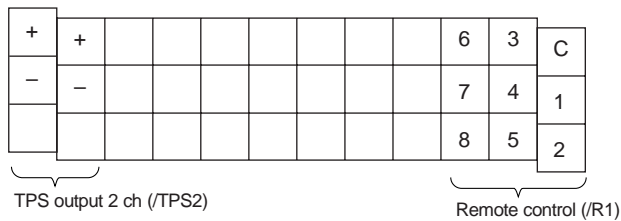

/TPS2 Combination

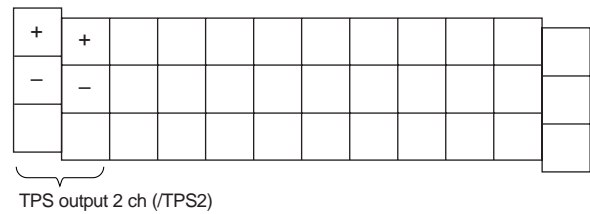

/R1/TPS4 Combination

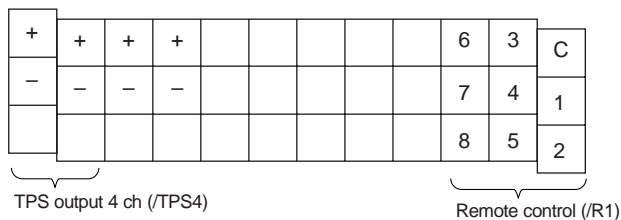

/TPS4 Combination

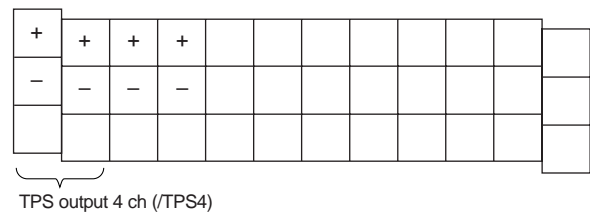

The TCP/IP software used in this product and the document for that TCP/IP software are based in part on BSD networking software, Release 1 licensed from The Regents of the University of California.

- Microsoft, MS and Windows are registered trademarks of Microsoft Corporation USA.
- Lotus and 1-2-3 are registered trademark of Lotus Development Corporation.
- MMX and Pentium are registered trademarks of Intel Corporation.
- Ethernet is a registered trademark of XEROX Corporation.
- Modbus is a registered trademark of AEG Schneider
- The Logo mark of FOUNDATION™ Fieldbus and Fieldbus foundation are registered trademark of Fieldbus foundation.
- Zip is a registered trademark of Iomega Corporation USA.
- Other company and/or product names are registered trade mark of their manufactures.